

SEWOO CO.,LTD

51 Gongdan 2-ro, Sanam-Myeon, Sacheon-City, Gyeong-Nam, Korea 52533
TEL : +82-55-854-0161~5 / FAX : +82-55-853-5048

SEWOO AEROSPACE CO.,LTD

23-17 Gongdan 1-ro, Sanam-Myeon, Sacheon-City, Gyeong-Nam, Korea 52531
TEL : +82-55-834-8490~2 / FAX : +82-55-834-8493



SEWOO

Aerospace Tubing & Welding Partner

Construction Equipment Hydraulic Pipe Partner



support@sewoo.biz
<http://www.sewoo.biz>

STRONG GLOBAL COMPANY

SEWOO

CONTENTS

Company Profile	03
History	03
Business Area	04
Aircraft / Aerospace Parts Business	04
Construction Equipment Parts Business	05
Major Products	06
Aircraft / Aerospace Products	06
Construction Equipment Products	10
Equipment	14
Manufacturing Process	18
Manufacturing Strengths	20
Vision	23



1985

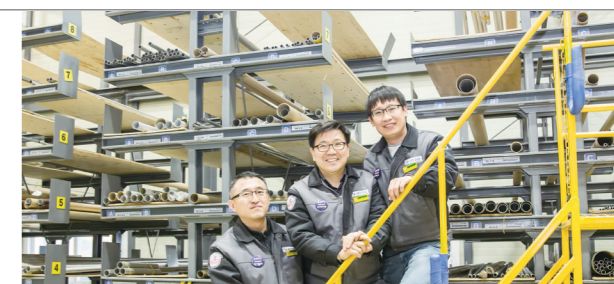

2016



- April, 1985** SEWOO established
- October, 2005** Started Aircraft Tube Fabrication for Korea Aerospace Industries. (KAI)
- November, 2007** Outstanding Quality Awards from KAI
- December, 2007** SEWOO AEROSPACE established (separated from SEWOO)
- April, 2008** AS9100 Accreditation
- April, 2009** ISO 14001 Accreditation
- June, 2009** Venture Business Certification acquired
- April, 2011** Performance of Excellence Award from KAI
- June, 2011** Established R&D Center
- December, 2012** Aluminum Fusion Welding & Inspection Process Approval by DATQ
- June, 2015** Performance of Excellence Award from KAI
- April, 2016** AS9100 Re-accreditation
ISO 14001 Re-accreditation
- December, 2016** NADCAP-Heat Treatment & Welding to be certified



Aircraft Aerospace Parts Business

BUSINESS AREA 01

- Hydraulic Line Tube Assembly
- Fuel Line Tube Assembly
- Environment Control System Line Tube Assembly
- Conduit for Wire Harness Tube Assembly
- Crew Ladder Welding Assembly
- Spoiler Beam Welding Assembly
- Air Duct Braiding Assembly



Aerospace Tubing & Welding Partner
Construction Equipment Hydraulic Pipe Partner

Connector for
Hydraulic
Assembly



Small and
Medium Tube
Assembly



High
Pressure Tube
Assembly



Aerospace
Tube
Assembly

Construction Equipment Parts Business

BUSINESS AREA 02

- Hydraulic Pipe Assembly
- Structural Pipe Assembly (Handrail & Guardrail)



Global Hydraulic Pipe Partner
Strong Global Company

Since established, we've done a technical revolution through technical expanding the global sales network to INDIA, RUSSIA and CANADA based on current EU, JAPAN, UK and US market experience. All staffs in SEW00 are doing their best to become one of the top global companies recognized by global customers.

Major Products

» Aircraft / Aerospace Tubing Assembly

- Hydraulic Lines
- Fuel Lines
- Environment Control System Lines
- Conduit for Wire Harness

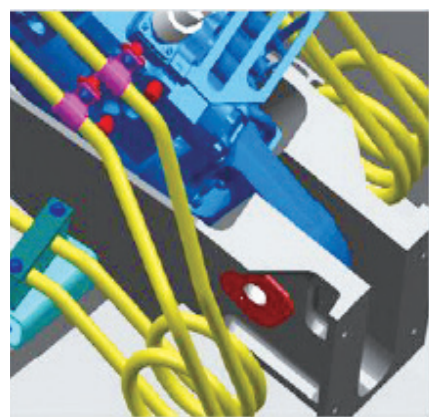
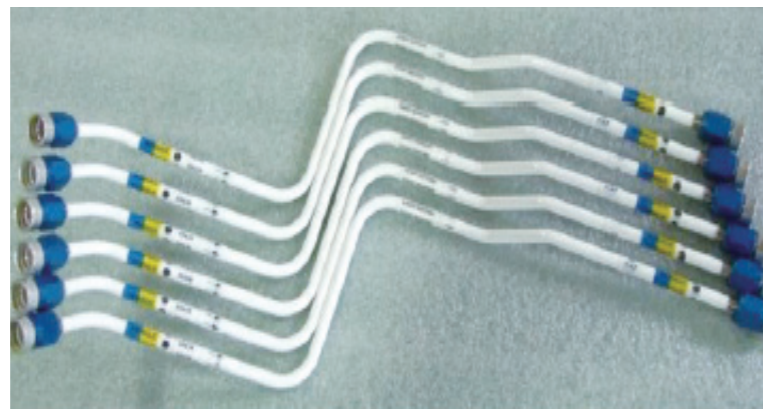
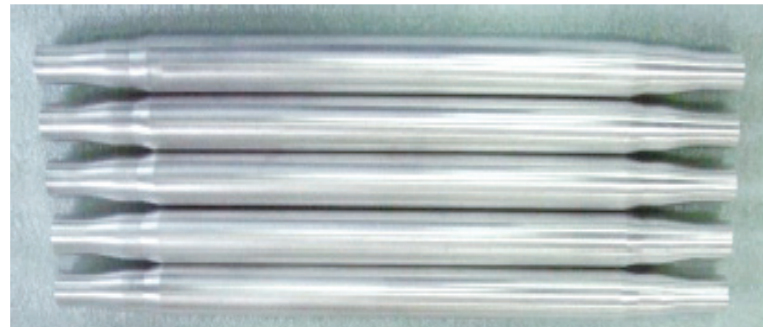
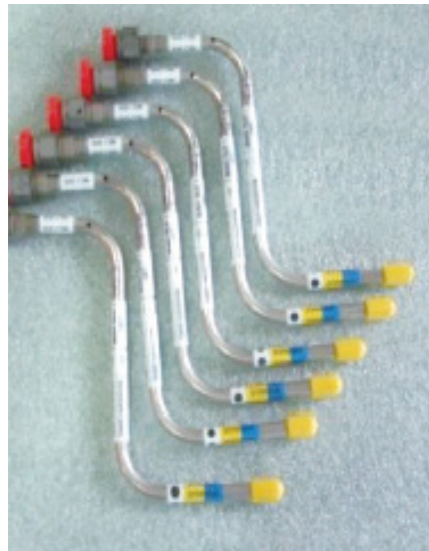
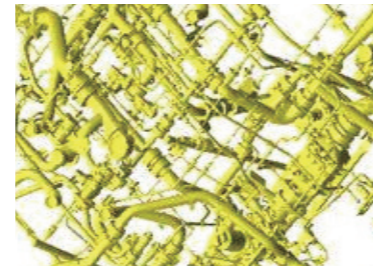

» Aircraft / Aerospace Welding Assembly

- Tubing assembly for wing



- Spoiler Beam Assembly

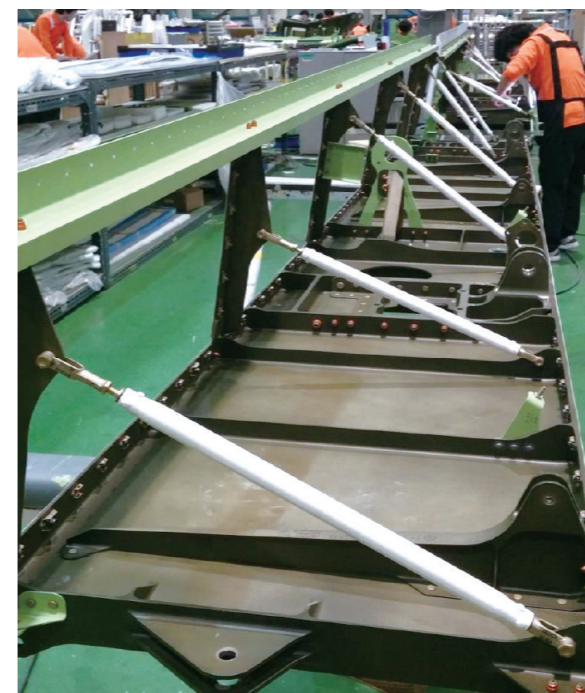

- Crew Ladder Welding Assembly



- Tube Welding Assembly

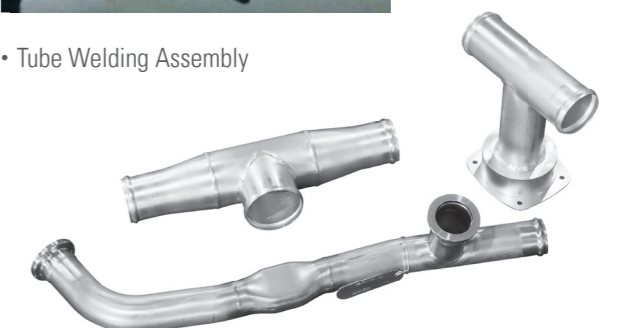

Major Products

» Aircraft / Aerospace Hot Air duct Assembly

- Hydraulic Lines
- Fuel Lines
- Environment Control System Lines
- Conduit for Wire Harness

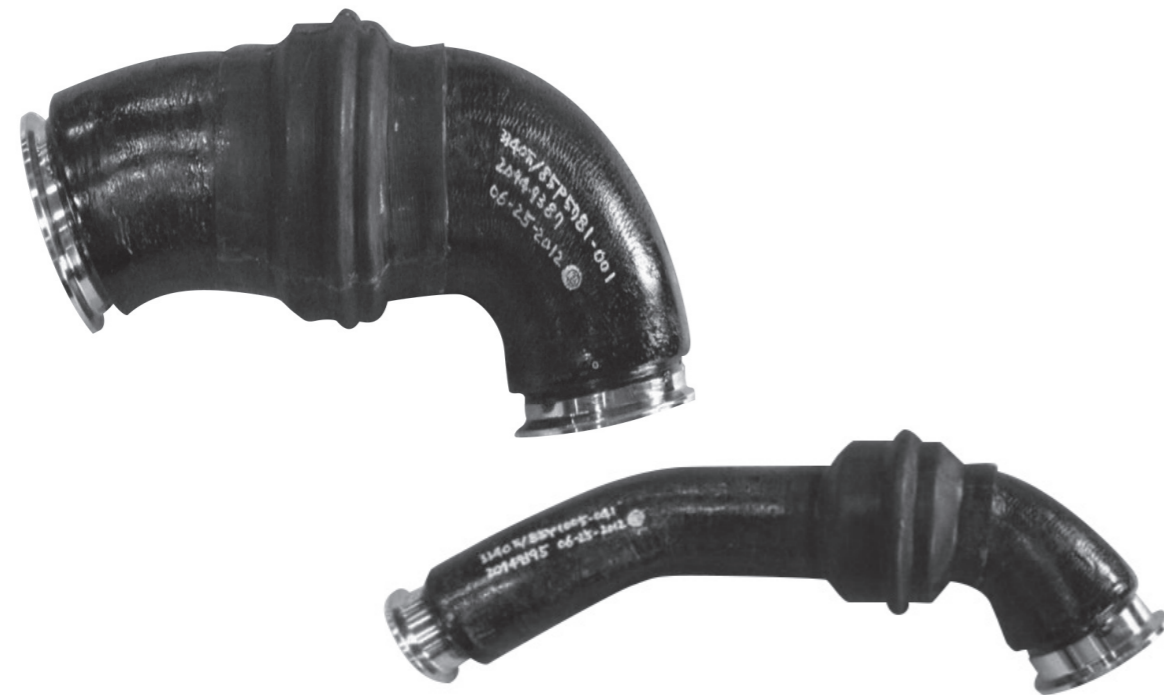

» 75t Engine Assembly & Clustering Model



» 7t Fuel & Lox High Pressure Pipe Assembly

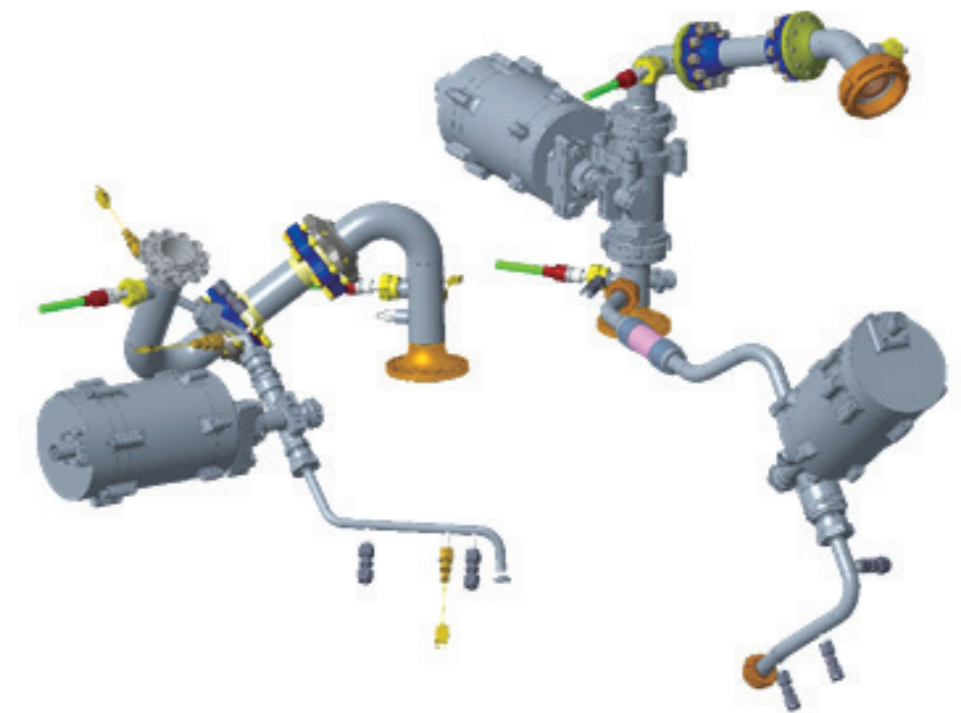

TUBE BENDING

WELDING

INSULATION APPLICATION

BRAIDING

Construction Equipment Pipe

Weldment Assembly

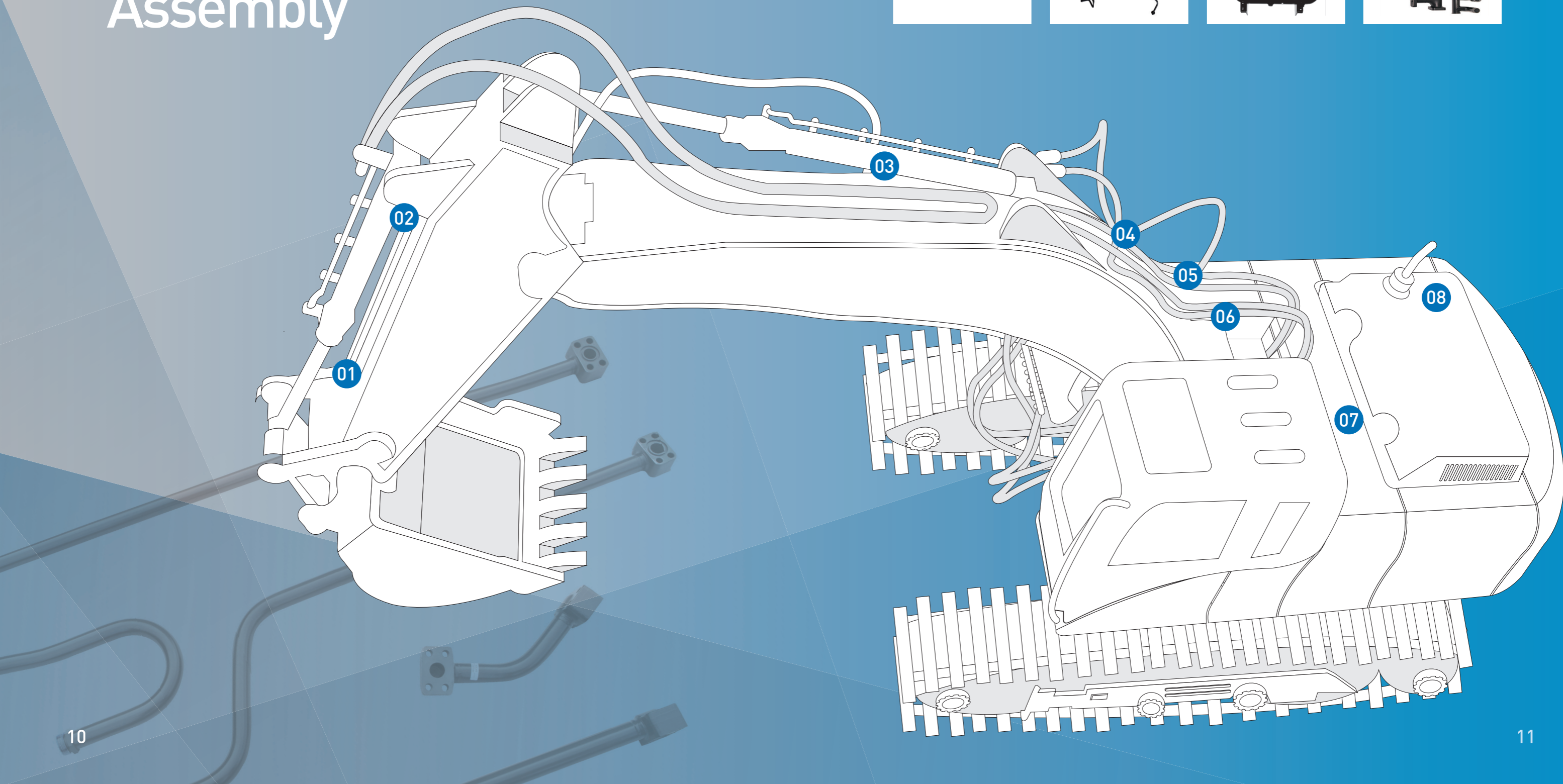
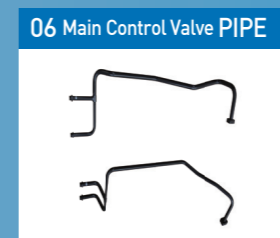
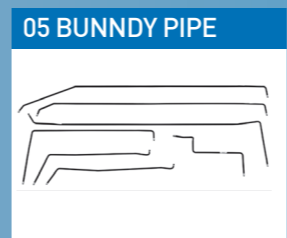
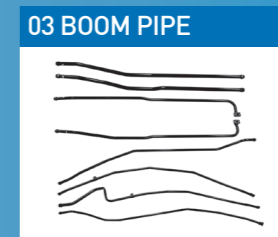

Major Products

» Hydraulic Cylinder Pipe & Weldment Assembly

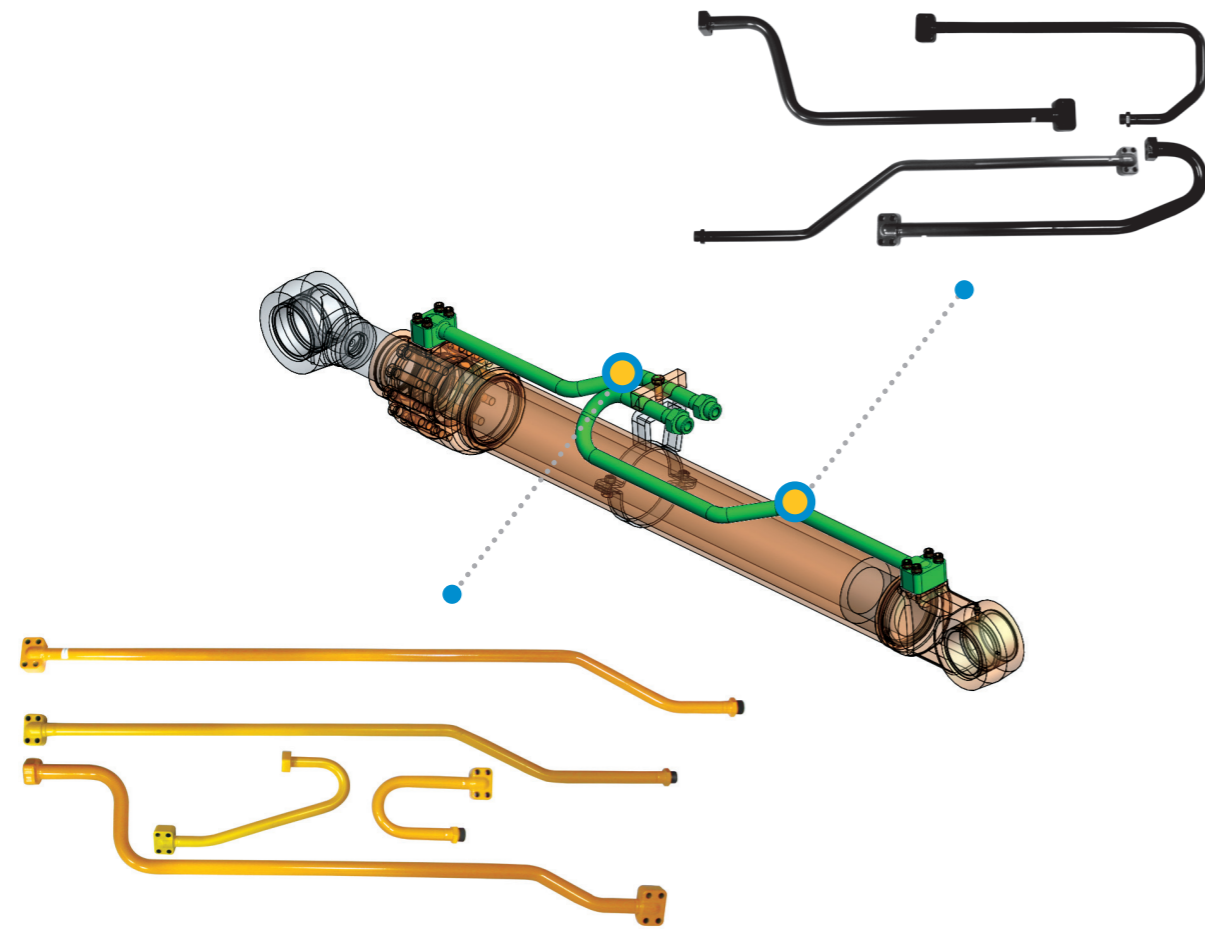

» Structural Parts

• HANDRAIL / GUARDRAIL

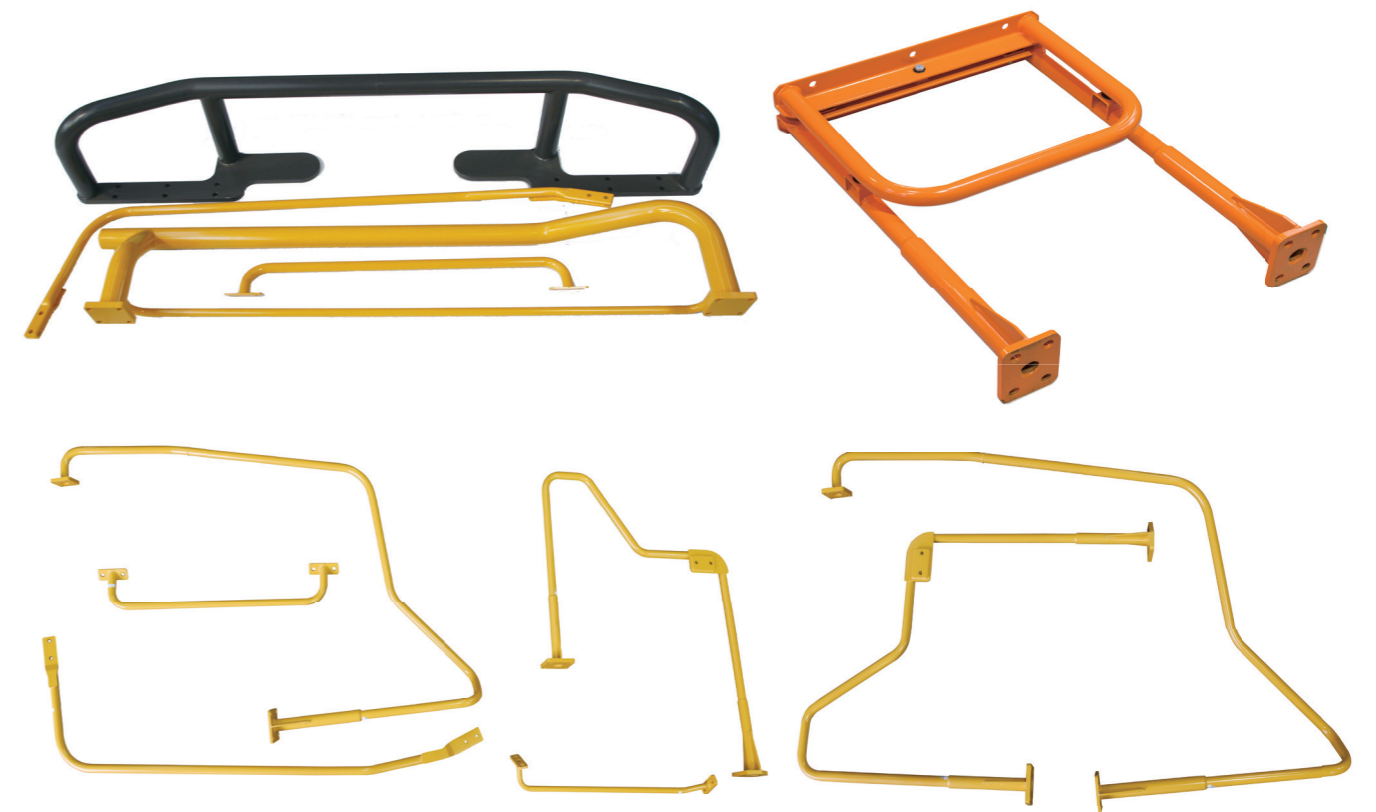

Equipment

01

Tube Cutting Machines



Capacity	
Diameter Size	Circular Tube 6~90mm
Cutting Length	30~7000mm
Accuracy	±0.15mm
Capability	Ø40 x 1.2t x 300L – 1000ea/h
Materials	Steel, aluminum, titanium, Inconel
Number of Unit	8 unit

02

CNC Bending Machines



Capacity		
EATON	300HP	1 unit
	100HP	2 unit
	75HP	1 unit
	VB25	1 unit
YLM	80CNC	4 unit
	70CNC	1 unit
	38CNC	2 unit
	25CNC	1 unit
TAYIO	60CNC	1 unit
	40CNC	1 unit

03

Full Automatic Welding Machines

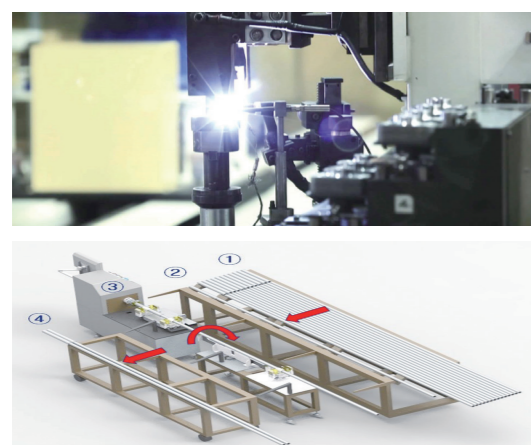

Capacity		
TIG	Automatic Vertical	26 unit
	Automatic Horizontal	4 unit
	Manual	7 line
	CO2	Manual
Cert.	Stainless Steel	
	Aluminum	
	Titanium	
	Nickel Alloy	

06

Ultrasonic Cleaning Facility & Heat Treatment

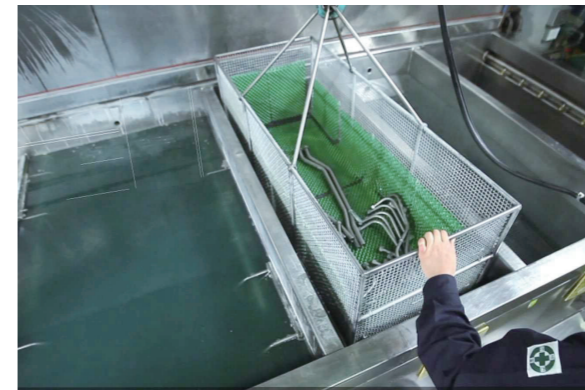

Ultrasonic Alkali Cleaning



Heat Treatment(100~550°C)

07

Full Automatic Surface Treatment & Painting Facility



Zinc phosphate surface Treatment



Electrostatic painting

08

Full Automatic Robot Production Line



Robot TIG Welding Assembly Line



Robot CO2 Welding Assembly Line

Equipment

09

Tube Swaging Machines

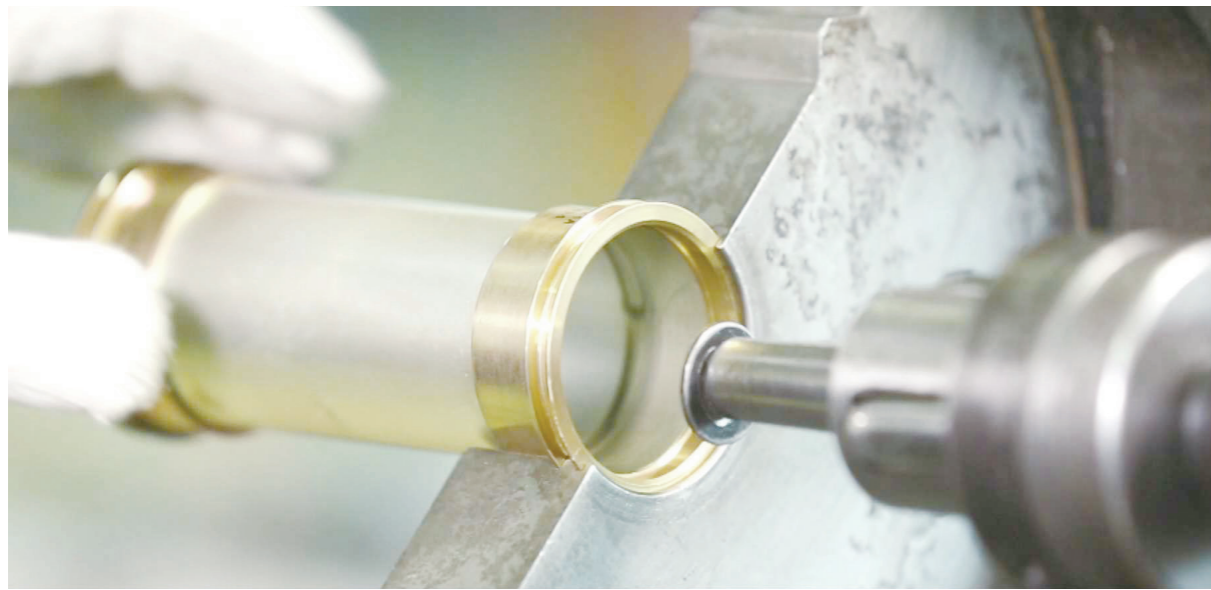

According to the assembly method of the aerospace tubing, We make the various shapes of the end points.

Capacity

Diameter Size	Circular Tube 10~90mm
Swaging machine	5 unit
Forming machine	4 unit

10

Braiding Machines

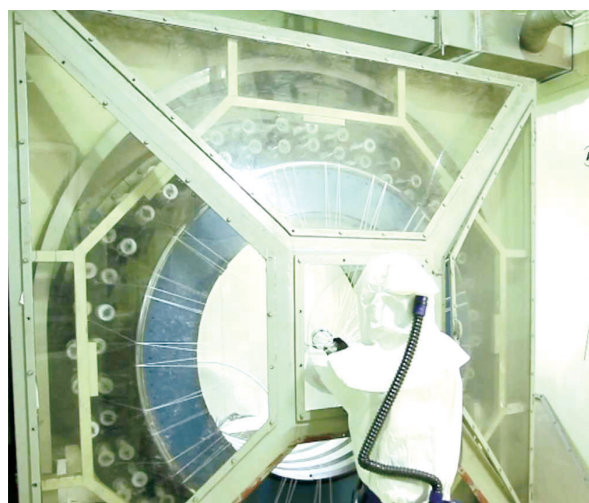

Duct for high temperature fuel line of the Engine.



Capacity

Diameter Size	Circular Tube 38~90mm
---------------	-----------------------

11

Inspection & Test Equipment



Shape Measuring Machine



Profile Projector



CMM



Microscope



Industrial Videoscope



Rockwell Hardness Tester



Vector Measuring Machine for Tube



Pressure testing equipment
Pneumatic : Max 200psi



Pressure testing equipment
Hydraulic : Max 10,000psi

Aircraft Aerospace Parts

All about tubing process from cutting to bending to welding and braiding.

01



MATERIALS

CUTTING

CNC BENDING

WELDING

INSPECTION

SHIPPING

PACKING

CLEANING

BRAIDING



Construction Equipment Parts

- Multiple items / small lot production system
- Short leadtime
- Tracking system with bar code

02

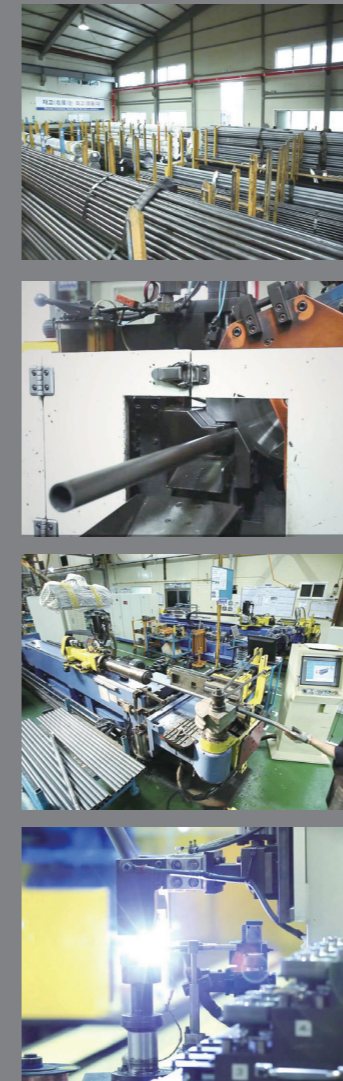

MATERIALS

CUTTING

CNC BENDING

WELDING

TESTING

SHIPPING

PACKING

PAINTING

SURFACE TREATMENT



Manufacturing Strengths

2 Head Automatic Pulse TIG Welding Equipment

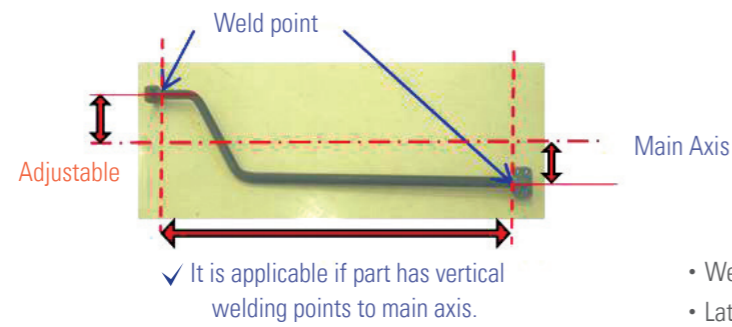
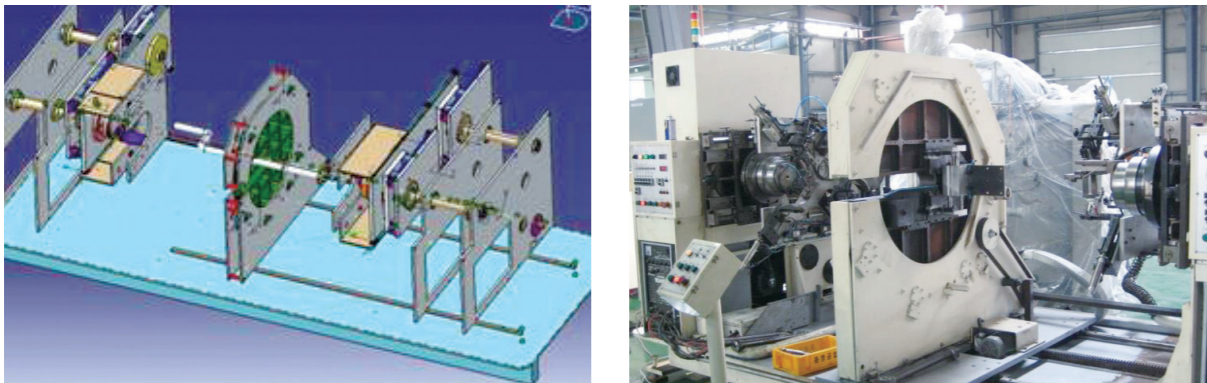

- Weld 2 points at the same time
- Laterally Adjustable at the same time

Quality Assurance System

- Quality Assurance System Setup by ISO 9001/AS 9100 Quality System
- Satisfy Customer's Tubing Specification
- Satisfy Welding Specification

Requirements

- Tube Bend Data
 - 2-D Drawing / Tube Mockup
 - MBD / CATIA Model
- Tubing Specification
- Welding Specification
- Customer's Requirements

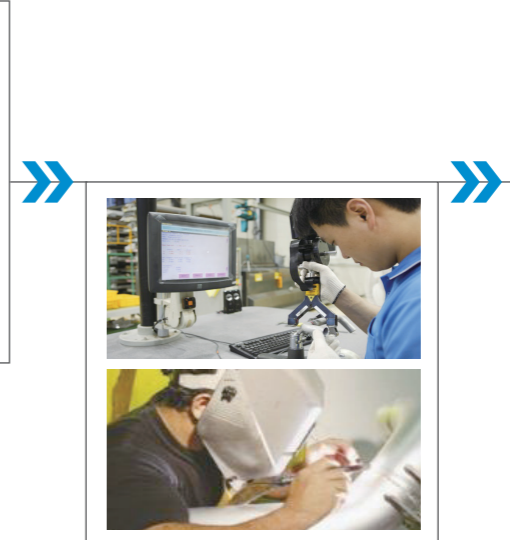

Quality Assurance

Certifications & Patent



AS9100



ISO14001

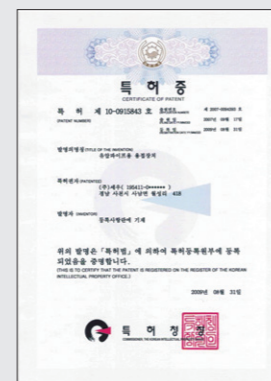

Patent granted

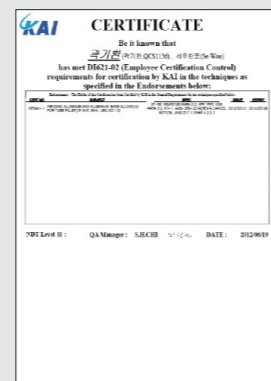

Welding Cert by KAI



Welding Cert by DTAQ in Korea



R&D center

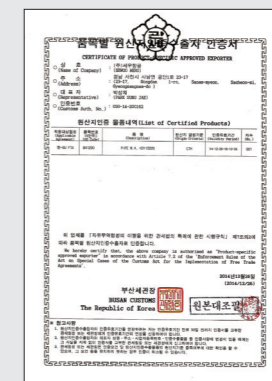

Product specific approved exporter

To be certified
Dec. 2016

- NADCAP Welding
- NADCAP Heat treatment

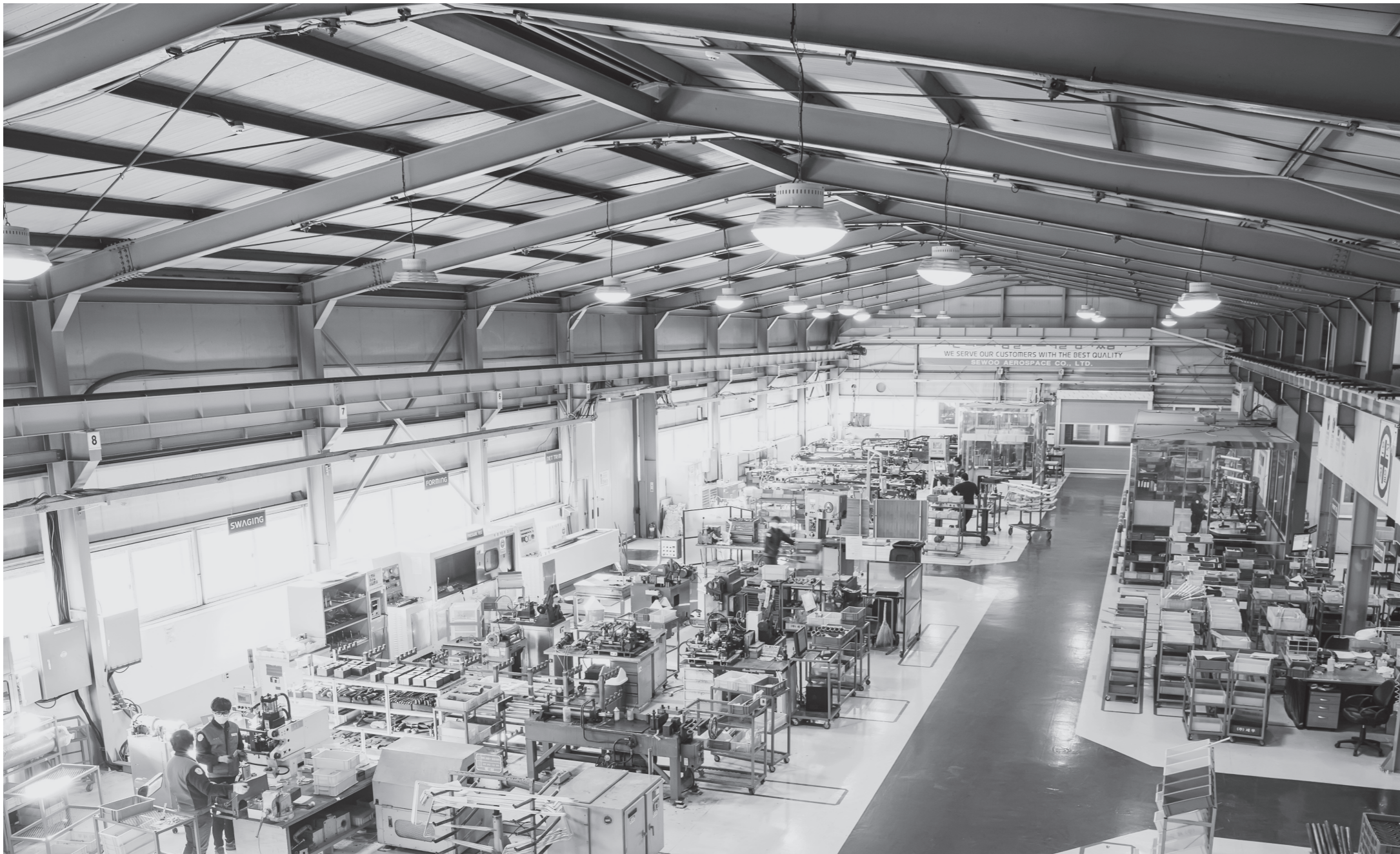

SEWOO Vision

A leading Global
Manufacturer of Tubing and
Piping Assembly

Operating markets

The present

Japan, China, Europe

Mid - and long-term goals

India, Russia, Brazil, Indonesia, North America

Message from the President & CEO

Respect for mankind is Sewoo's management philosophy. This philosophy has made true communication possible among the all employees Which in turn creates high-quality products that gain the trust of our customers. Sewoo will continuously work to provide products that satisfy customers' expectation.



*Sincerely,
Hae-Sool Park*

Five major innovation challenges

